

ART. 462-N

Contatto magnetico in alluminio / Aluminium magnetic contact

**SPECIFICHE GENERALI
GENERAL SPECIFICATIONS**

Materiale contenitore Housing material	Alluminio pressofuso Die-cast aluminium
Funzionamento Operation	NC con i due componenti vicini NC when the two components are near
Temp. di funzionamento Operating temperature	-25°C ÷ +50°C
Grado di protezione IP degree	Certificato IPx2 (dichiarato IP34 da Cooper CSA) Certified IPx2 (declared IP34 by Cooper CSA)
V max	42,4 Vpeak - 60 Vdc
I max	1 A
W max	10 W
Identificazione Identification	Numero seriale/lotto su ogni componente Serial number/batch on each component

I contatti magnetici sono componenti passivi, le grandezze elettriche indicate sono le massime applicabili
Magnetic contacts are passive components, max applicable voltage and current are displayed in table

EN50131-2-6

GR 2

CL III



**INSTALLAZIONE CONFORME ALLA NORMA
INSTALLATION AS PER STANDARD**

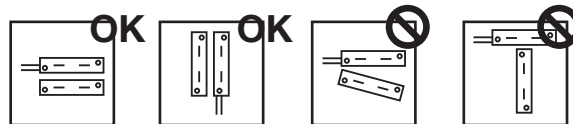
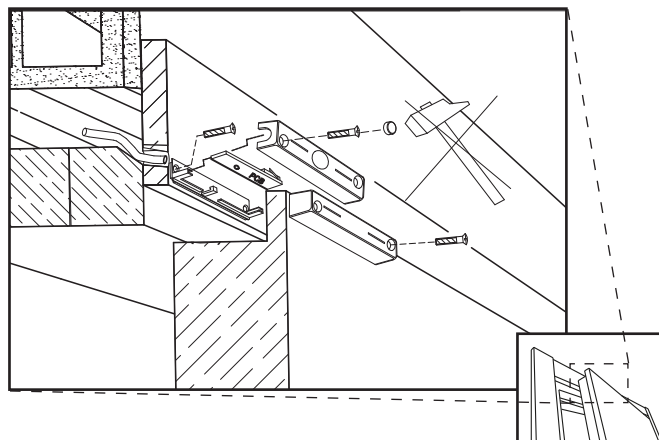

La certificazione decade per installazioni diverse da quelle rappresentate nelle figure.
Certification is void if the devices are installed differently.

DISTANZE OPERATIVE / OPERATIONAL APPROACH AND REMOVAL DISTANCES

Su superfici non ferromagnetiche installare i due corpi a distanza Y inferiore a 30mm (distanza raccomandata 9mm), su superfici ferromagnetiche a distanza Y inferiore a 25mm (distanza raccomandata 8mm). Le distanze operative riportate in tabella per gli assi X e Z sono state calcolate con i corpi installati alla distanza raccomandata.

Install the two components at Y distance less than 30mm (recommended 9mm) on non-ferromagnetic surfaces, at Y distance less than 25mm (recommended 8mm) on ferromagnetic surfaces. The operating distances displayed in table for axes X and Z have been calculated with the components mounted at the recommended distance.

Asse / Axis	Z+		Z-		X+ / X-		Y	
Azione Action								
Contatto Contact								
Superfici non ferromagnetiche Non-ferromagnetic surfaces	19 mm	28 mm	42 mm	61 mm	17 mm	25 mm	30 mm	44 mm
Superfici ferromagnetiche Ferromagnetic surfaces	16 mm	24 mm	24 mm	36 mm	16 mm	19 mm	25 mm	33 mm
Tolleranze / Tolerance	-0% +30%	+0% -30%	-0% +30%	+0% -30%	-0% +30%	+0% -30%	-0% +30%	+0% -30%

INDICAZIONI DI FISSAGGIO / FIXING INSTRUCTIONS

Fissare i componenti tenendo conto delle distanze operative riportate in tabella. Fissare il supporto del circuito con le viti in dotazione. Per i componenti utilizzare viti autofilettanti $\varnothing 3,5 \div 3,9$. Inserire i tappi a protezione delle viti di fissaggio.

Fix the components paying attention to the operational approach and removal distance. Fix the support of the PCB using the included screws. For the components use $\varnothing 3.5 \div 3.9$ tapping screws. Insert the plugs to protect the screws.

MORSETTI / TERMINALS

