

DH-PFB301C

Ceiling Mount Bracket



Features

- Material: Aluminum & PC
- Wall Mount Bracket
- Neat & Integrated design

Specifications

Model	DH-PFB301C
General	
Material	Aluminum & PC
Dimension (W x H x D)	Φ133mm(W) x 41mm(H)
Pipe Thread	1 1/2" PF
Operating Temperature	-40°C ~60°C
Humidity	0~90% RH
Load Bearing	7.0Kg
Weight	0.25kg
Applicable Model	PFA100, PFA101, PFA102, PFA110, PFA111, PFA114

DH-PFB301C

Dimensions (mm)

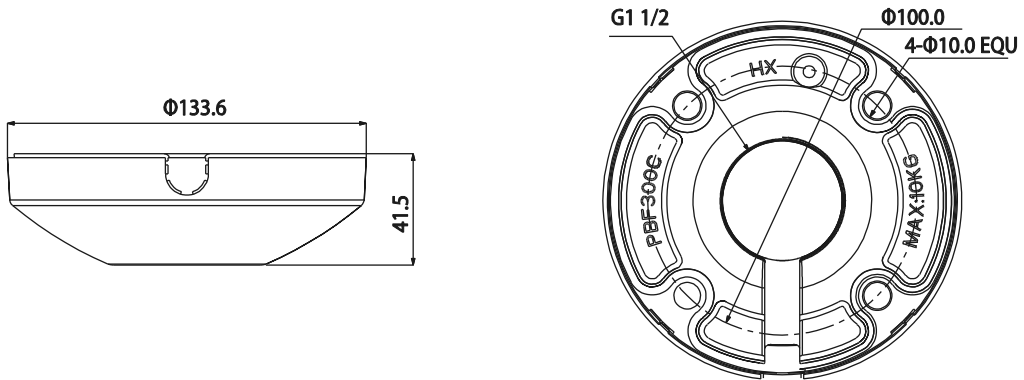

Application

